

## Parts List

Revision 5/30/24

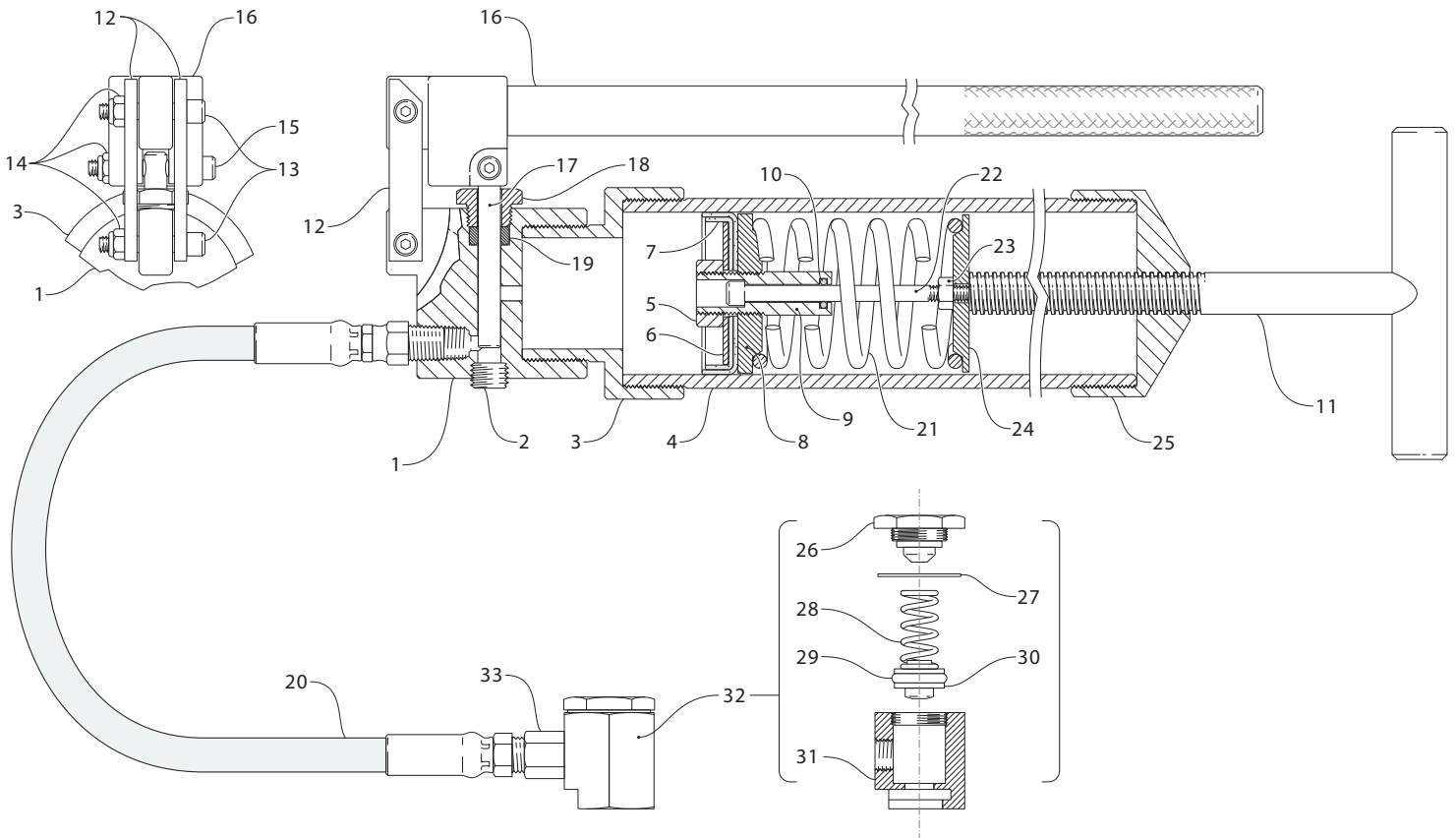

## Parts List 10700 / 10710

Key	Description	Part No.
1	Head	10601
2	Plug	10602
3	Barrel Adapter	10676
4	Barrel	10659
5	Piston Jam Nut	10827
6	Fender Washer	10647
7	Primer Cup	10646
8	Spring Adapter	10939
9	Piston Rod	10941
10	"O" Ring	10842
11	Screw Handle	10612
12	Link (2 Required)	10613
13	Stripper Bolt (2 Required)	10614
14	Lock Nut (3 Required)	10778

## Parts List 10700 / 10710 (continued)

Key	Description	Part No.
15	Stripper Bolt	10779
16	Plunger Handle	10617
17	Plunger	10618
18	Packing Nut	10619
19	Packing	10621
20	Hose 18"	10631
21	Primer Spring	10652
22	Screw: 1/4-20 NC	10938
23	Nut: 1/4-20 NC	10608
24	Spring Adapter	10942
25	Collar	10661
26	Coupler Cap	10623
27	Coupler Gasket	10624
28	Coupler Spring	10625

## Parts List 10700 / 10710 (continued)

Key	Description	Part No.
29	Coupler "O"-Ring	10626
30	Coupler Piston (Nylon)	10627
31	Coupler Body	10628
32	Coupler G.B.H.	10630
33	Coupler Adapter	10629

## Features

- Hardened, one piece precision ground plunger
- High strength screw handle
- Premium primer die spring
- Adjustable plunger packing

Made in  
the USA

Producing Professional lubrication products since 1960. Products are made and assembled in the USA. 100% Repairable and Recyclable.



© 2024 Dualco, Inc

8404 Braniff  
Houston, Texas 77061  
713-644-1164 • FAX 713-644-7761  
www.dualco-inc.com