

Revision 5/30/24

**General Parts Diagram**

**•10,000psi Models:**  
10610, 10610HDC,  
10635, 10645, 10655,  
10655HDC, 10675, 10690  
(Example shown is 10610)

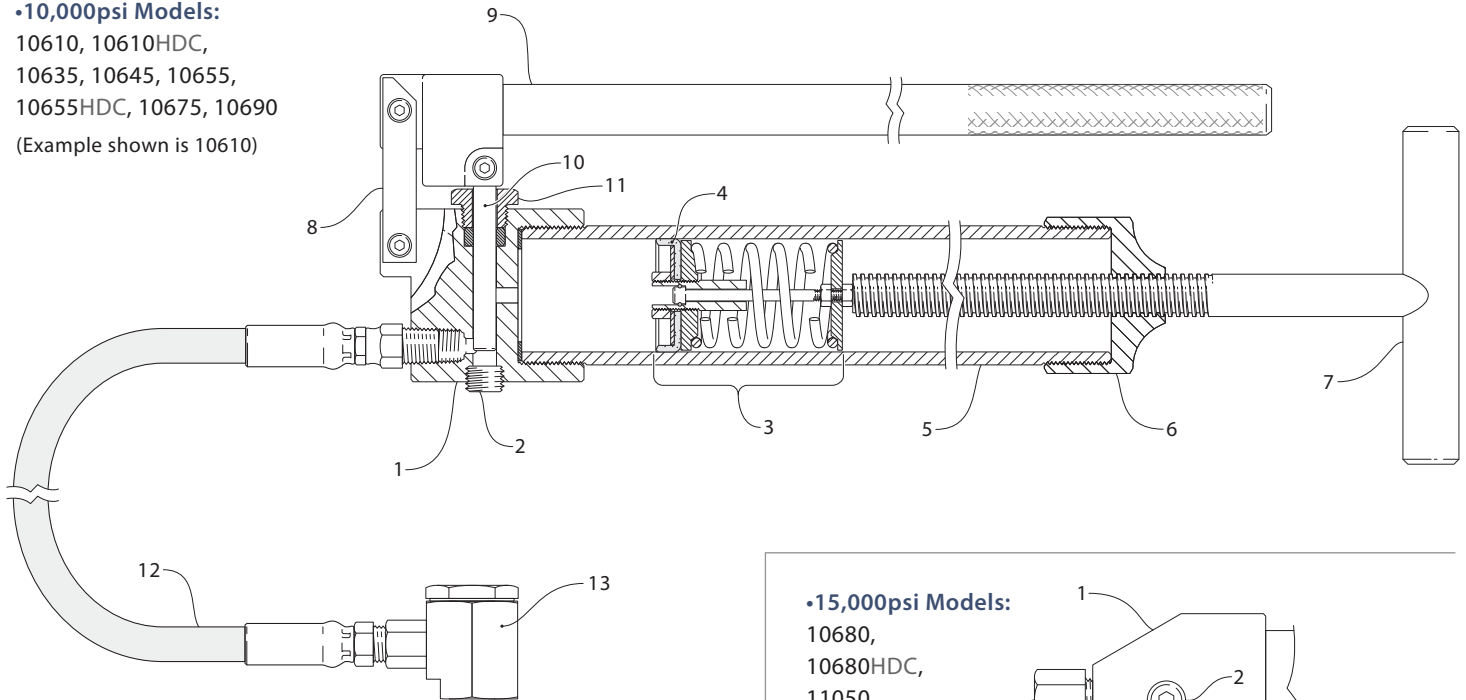

**! Safety First!**  
Use only Genuine Dualco Parts.  
Contact Dualco for repair, or rebuilding  
procedures.

**•15,000psi Models:**  
10680,  
10680HDC,  
11050,  
11070

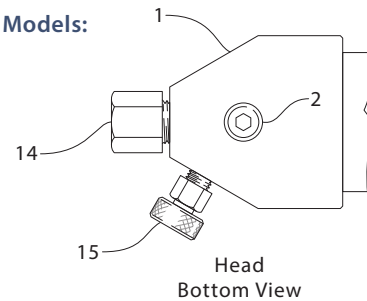

**General Parts List**

Key	Description	Part No.
1	Head	10601
2	Plug	10602
3	Primer Spring Assembly (Includes Primer Cup)	11810
4	Primer Cup	10894
5	Barrel	10609
6	Collar	10611
7	Screw Handle	10612
8	Link (2 Required)	10613

**General Parts List (continued)**

Key	Description	Part No.
9	Plunger Handle	10617
10	Plunger	10618
11	Packing Nut	10619
12	Hose	Varies with Model
13	Coupler G.B.H.	Varies with Model
15,000psi models:		
14	Spring Retainer Adapter	10634
15	Pressure Relief Valve	11180

This List is a general guideline for instructional purposes. For detailed model specific parts diagrams, or any other questions please contact us.



Producing Professional Lubrication products since 1960. Products are made and assembled in the USA. 100% Repairable and Recyclable.



Revision 5/30/24

## Includes

- 10,000psi Models:  
10610, 10610HDC, 10635, 10645,  
10655, 10655HDC, 10675, 10690
- 15,000psi Models:  
10680, 10680HDC, 11050, 11070



Read complete instructions before using this Gun.

### Part 1. Operation & Description

All models of the DUALCO Grease Gun are high-pressure tools that should be used with caution and according to these instructions.

**IMPORTANT** • Do not exceed 10,000 psi for most models, or 15,000 psi for models 10680, 10680HDC, 11050 and 11070.

During operation, lever action of the Plunger Handle (9) causes the Plunger (10) to move in and out of the Head (1). As the Plunger (10) goes into the Head (1) it forces the material lubricant (packing, sealant or cleaner) from the Barrel (5) out through the Head (1) discharge port. Numerous options are available for Head (1) attachments to transmit material to the desired pump, valve, or other equipment. Be sure to have the appropriate material transmission apparatus or hose assembly firmly attached to Head (1) before Gun operation.

The (numbers) shown herein refer to included general parts list.

To ensure the DUALCO Grease Gun will perform and operate properly, use after use, keep the gun out of the weather, clean and maintained.

Always make sure the Head (1) and Collar (6) are firmly attached to the Barrel (5) and be sure there is full thread engagement between these parts before Gun operation.

Each new DUALCO Grease Gun is ready to use, following this procedure:

### Part 2. Loading

A. To load the DUALCO screw prime, lever operated Grease Gun(s) with lubricant, sealant, or cleaner) UNSCREW Barrel (5) Assembly from the Head (1) counter-clockwise until it comes free.

B. Turn Screw Handle (7) counter-clockwise completely out until it stops.

C. Insert a "J" Stick, "K" Stick, Gun Bag or bulk material into the Barrel (5).

D. Screw Barrel (5) Assembly clockwise into Head Assembly (1). Make sure Barrel (5) is firmly seated in the Head Assembly (1).

E. Turn Screw Handle (7) clockwise, so the Primer Spring Assembly (3) fully compresses material to be pumped. For 15,000psi models, cycle the Pressure Release Valve (15) open, then closed.

F. Connect Giant Button Head Coupler (13) to a Giant Button Head Fitting on a valve and stroke Plunger Handle (9) to pump lubricant (packing, sealant or cleaner) into fitting.

G. As the Gun loses its prime or is no longer pumping material, repeat steps E thru G.



To remove the Gun from operation, make sure there is no back pressure. **Always** Back-off (turn counter-clockwise) the Screw Handle (7), and for 15,000psi models, open the Pressure Release Valve (15) (counter-clockwise).

**IMPORTANT** • Warranty will be voided if Gun is altered **IN ANY WAY**.

**NOTE** • For technical assistance regarding any other operation, repair, or rebuilding procedure, contact DUALCO service department; [dualco@dualco-inc.com](mailto:dualco@dualco-inc.com) or 713-644-1164



Producing Professional Lubrication products since 1960. Products are made and assembled in the USA. 100% Repairable and Recyclable.

