

Revision 6/12/24

Parts Diagram

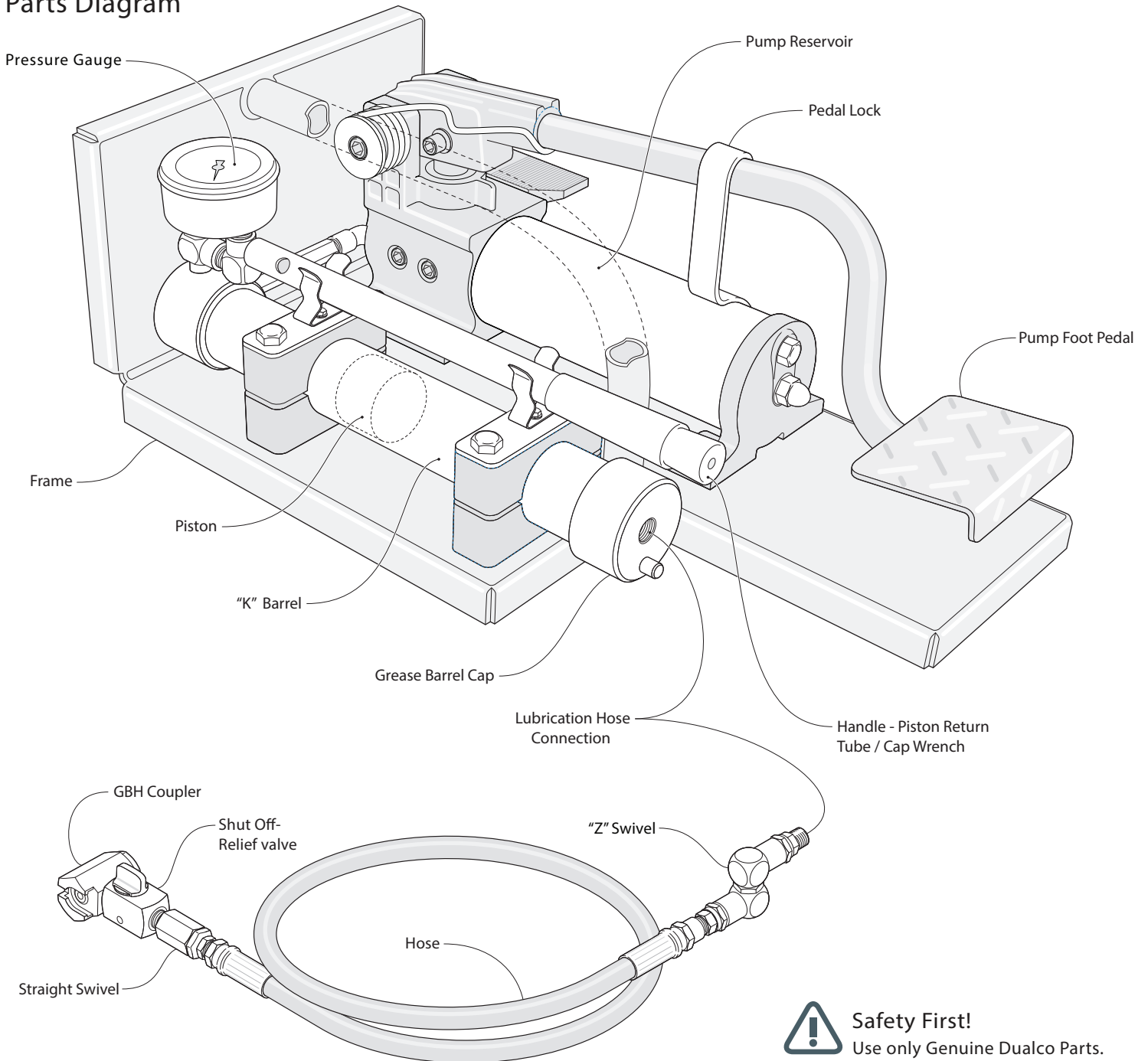

Safety First!

Use only Genuine Dualco Parts. Contact Dualco for repair, or rebuilding procedures.



Producing Professional lubrication products since 1960. Products are made and assembled in the USA. 100% Repairable and Recyclable.

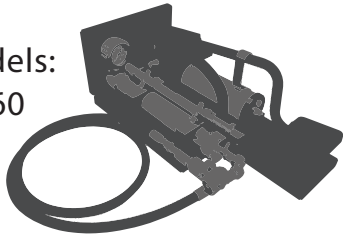

Revision 6/12/24

Includes Models:
11725 & 11660

Read complete instructions before using this Gun.

- For Professional Use Only •

Part 1. Operation & Description

All models of the DUALCO Foot-Operated Hydraulic Injection Gun are high-pressure tools that should be used with caution and according to these instructions.

IMPORTANT - Do not exceed 10,000 psi for models 11660 and 11725.

These Injection Guns transmit material (lubricant, packing, sealant or cleaner) by the use of manual foot actuated hydraulic pump driving a hydraulic/lubricant Cylinder.

During operation, pumping the Foot Pedal causes hydraulic fluid to flow from the Pump Reservoir into the "K" Barrel. The pressurized Hydraulic Fluid forces the Piston inside the barrel forward, allowing grease to pump out the end of the hose. Other options are available for attachments to transmit material to the desired pump, valve, or other equipment. Be sure to have the appropriate material transmission apparatus or hose assembly firmly attached to Grease Barrel Cap before Gun operation.

To ensure the DUALCO Foot Operated Hydraulic Injection Gun will perform and operate properly after use, keep the gun out of the weather, clean and well maintained.

Part 2. Loading

Each new DUALCO Injection Gun is ready to use, following this procedure:

1. Make sure the gun is lying down horizontal. Depress the Foot-Pedal with your right hand and twist the Pedal Lock towards the pedal with your left.
2. Now that the Foot-Pedal is locked in position, stand the unit up vertical.

Part 2. continued

3. Turn the Grease Barrel Cap (with Hose Assembly) counter-clockwise from the Barrel. Remove completely. (See Page 4)
 4. Remove the Handle from the Clips and push downward on the Piston, which is located inside the Barrel. Make sure the piston travels all the way down until it stops. (See Page 5) The handle has a side hole near the threaded end, which will fit over the pin in the Grease Barrel Cap. Using the Handle in this manner makes it a convenient tool to loosen and tighten the Cap. The Handle is marked with approximate 1-ounce graduations for measuring material.
 5. Load either a "J" or "K" Stick of Lubricant, Sealant or Packing in the Barrel. (See Page 6)
 6. Replace the Grease Barrel Cap (with Hose Assembly) and turn clockwise until tight.
- IMPORTANT** - Always make sure the Grease Barrel Cap is firmly attached to the Grease Barrel, and be sure there is full thread engagement between these two parts before each Gun operation.
7. Lay down the gun horizontal. With your right hand, depress Foot-Pedal and twist the Pedal Lock away from the pedal with your left hand. This will allow the Foot-Pedal to spring-up to a level "priming" position.
 8. Place your foot on the square part of the Foot Pedal and apply pressure.
 9. Continue pumping until a steady stream of material is discharged from the Giant Button Head Coupler.
 10. Connect the Giant Button Head Coupler to the correct fitting and pump the Foot Pedal until the correct amount of material is injected.
 11. Once your job is complete, turn the Shut Off-Relief valve counter-clockwise ¼ turn, releasing pressure from the Giant Button Head Coupler.
 12. Remove the Giant Button Head Coupler from fitting and turn the Shut Off-Relief valve clockwise one ¼ turn.
 13. Coil-up your Hose and store in the middle of the Gun Assembly.

IMPORTANT - Prior to removing the Gun from operation, first make sure there is no back pressure.



Producing Professional Lubrication products since 1960. Products are made and assembled in the USA. 100% Repairable and Recyclable.



8404 Braniff
Houston, Texas 77061
713-644-1164 • FAX 713-644-7761
www.dualco-inc.com

© 2024 Dualco, Inc

Part 3. Maintenance

- Any repair or service requiring disassembly of the DUALCO Foot-Operated Hydraulic Injection Gun must be performed in a dirt-free environment by a qualified DUALCO technician with proper instructions.
- Dispose of used parts, lubricants, and fluids properly. It is wise to use environmentally safe cleaning solvents.
- Be sure to contact DUALCO if there is ever an operational problem, or if there are any questions.

Item 1.

Injection Fluid

The DUALCO Foot-Operated Hydraulic Injection Gun comes filled with DUALCO hydraulic oil. Oil should be added or replaced as necessary using only DUALCO hydraulic oil. Do not contaminate or use any other fluid. Check the oil level in the Pump reservoir after every 10 hours of use. Drain and replenish the Pump reservoir with DUALCO hydraulic oil as specified. The oil is available in several size containers up to 55-gallon drums.



WARNING - Read Safety Data Sheet and DUALCO Injection Fluid label before use.

Item 2.

Refilling the DUALCO Foot-Operated Hydraulic Injection Gun with Injection Fluid and purging the system of air:

A. During the first moments of operation or after prolonged use, air may accumulate within the system. This entrapped air may cause the cylinder to respond slowly or behave in an unstable manner. To remove the air, run the system through several cycles (extending and retracting the cylinder) free of any load. The cylinder must be at lower level than the Pump to allow air to be released through the Pump reservoir.

B. Clean the entire area around the Pump filler plug before adding fluid to the Pump reservoir. Remove the Pump filler plug, and insert a clean funnel with filter. The cylinder must be fully retracted when adding fluid to the Pump reservoir.

Item 3.

Periodic Cleaning

IMPORTANT - The greatest single cause of failure in hydraulic pumps is dirt. Keep the Pump and attached equipment clean, to prevent foreign matter from entering the system.

- A routine should be established to keep the Pump as free from dirt as possible. All unused couplers must be sealed with thread protectors. All Hose connections must be free of dirt and grime. Any equipment hooked up to the Pump should also be kept clean.
- Use only DUALCO hydraulic oil in this Pump and change as recommended.

Item 4.

Draining and Flushing the Pump Reservoir:



IMPORTANT - Wipe the Pump exterior completely clean before attempting this procedure.

- Drain and clean the other Hydraulic System components (hoses, cylinders, etc.) before reconnecting them to the Pump. This will prevent contaminated fluid from entering the Pump again.
- Warranty will be voided if the Pump Internal Relief Valve or other Gun components are altered, disassembled, or tampered with. Warranty will be voided if Gun is altered.



WARNING: Be familiar with all product and Pump warranties, maintenance-care procedures, and warnings before use.

- Always wear proper personal protective gear when operating equipment, such as safety glasses, gloves, hearing protection, etc. Do not disassemble this Gun, or warranty will be voided.

Note:

Contact DUALCO for technical assistance regarding other operation, repair, or rebuilding procedures.

Revision 6/12/24

⚠ Safety First!

Read complete instructions
before using this Gun.



Be sure the Release Valve
Pedal is locked in position
Before tipping.

1. Start by tipping the 11725 on its end.

2. Remove Cap

Turn Counter-clockwise.
Use Piston Return
Tube / Cap Wrench
if required

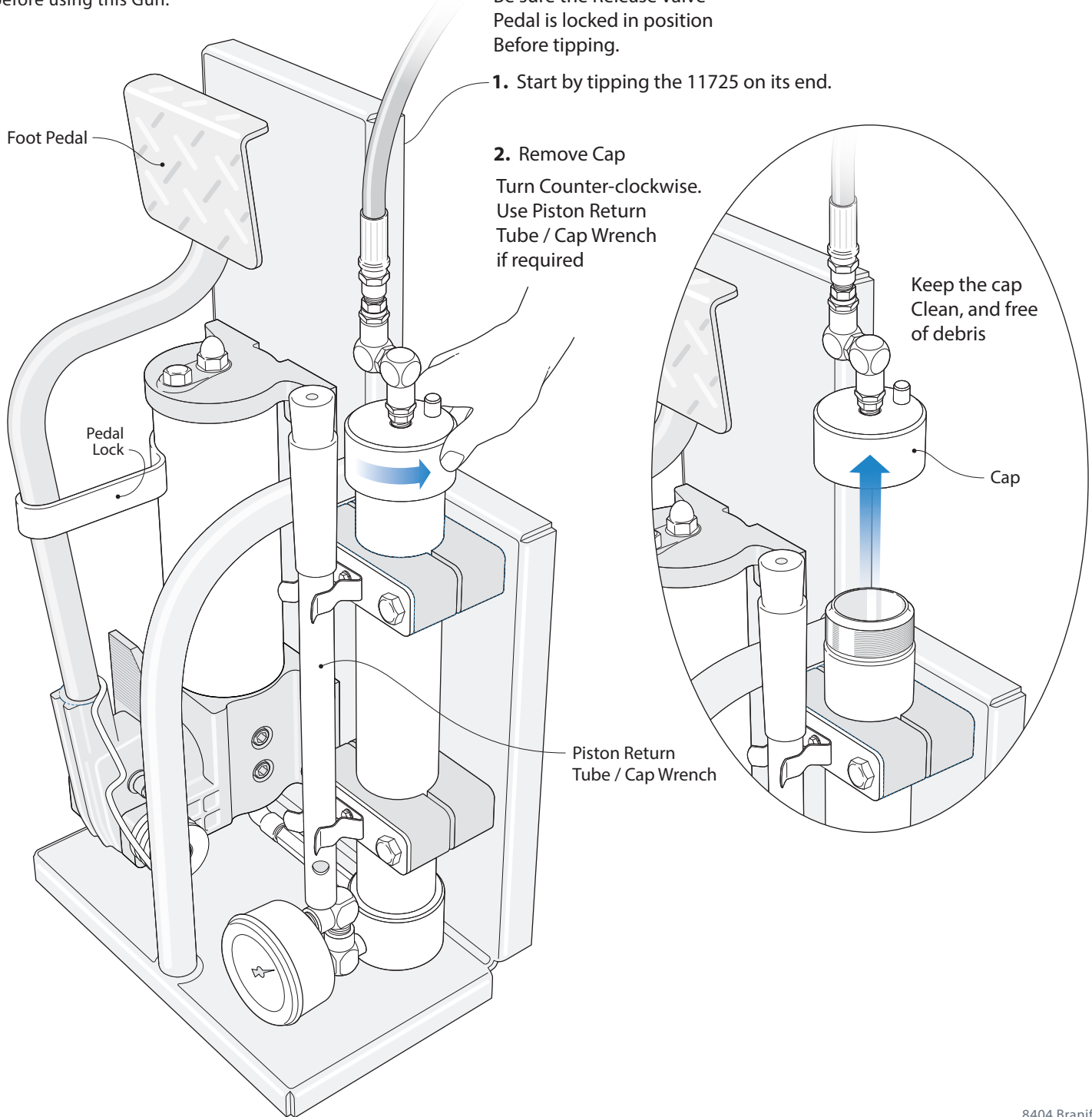

Made in
the USA



Producing Professional Lubrication products
since 1960. Products are made and assembled
in the USA. 100% Repairable and Recyclable.



DUALCO[®]

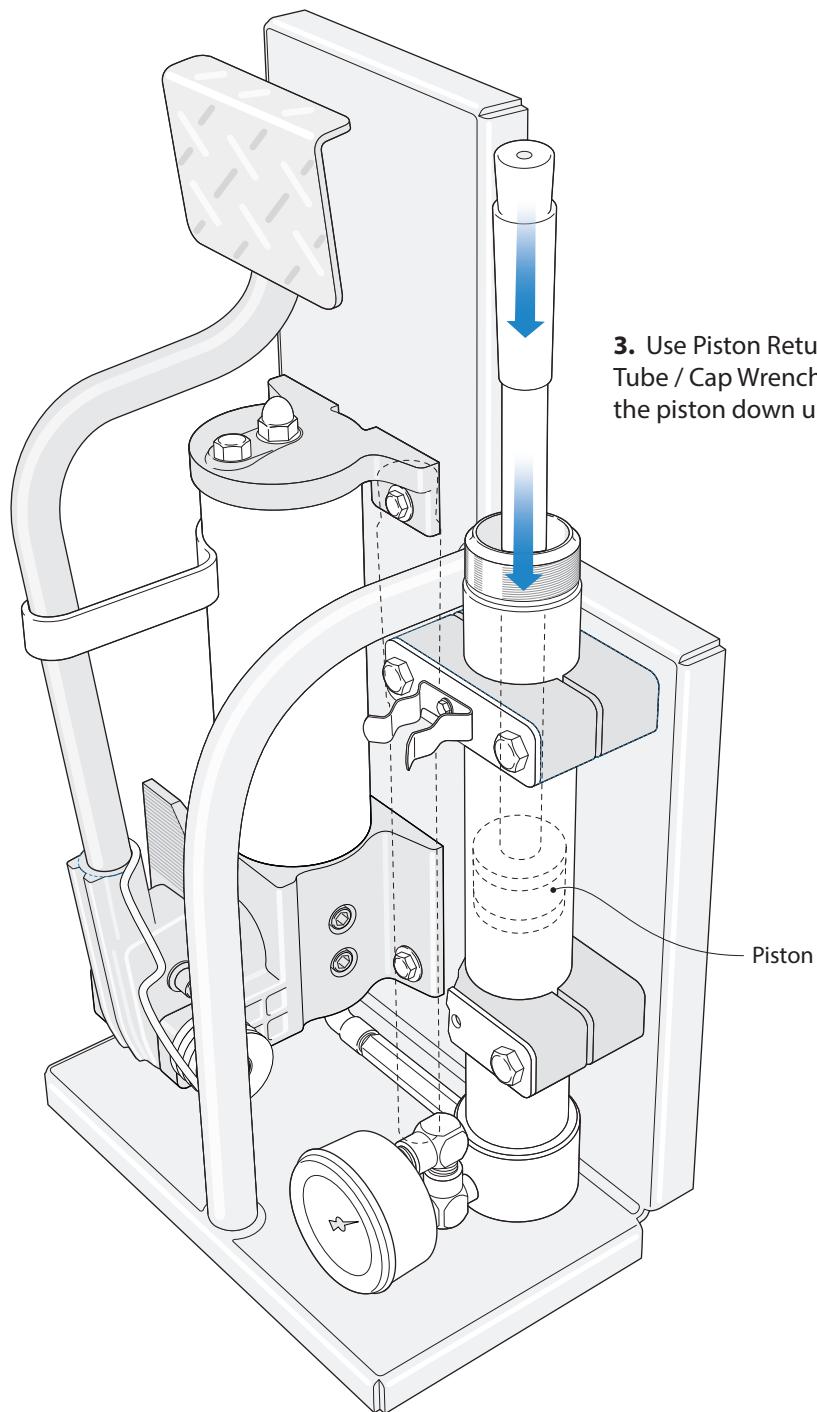

3. Use Piston Return Tube / Cap Wrench to push the piston down until it stops.

Piston

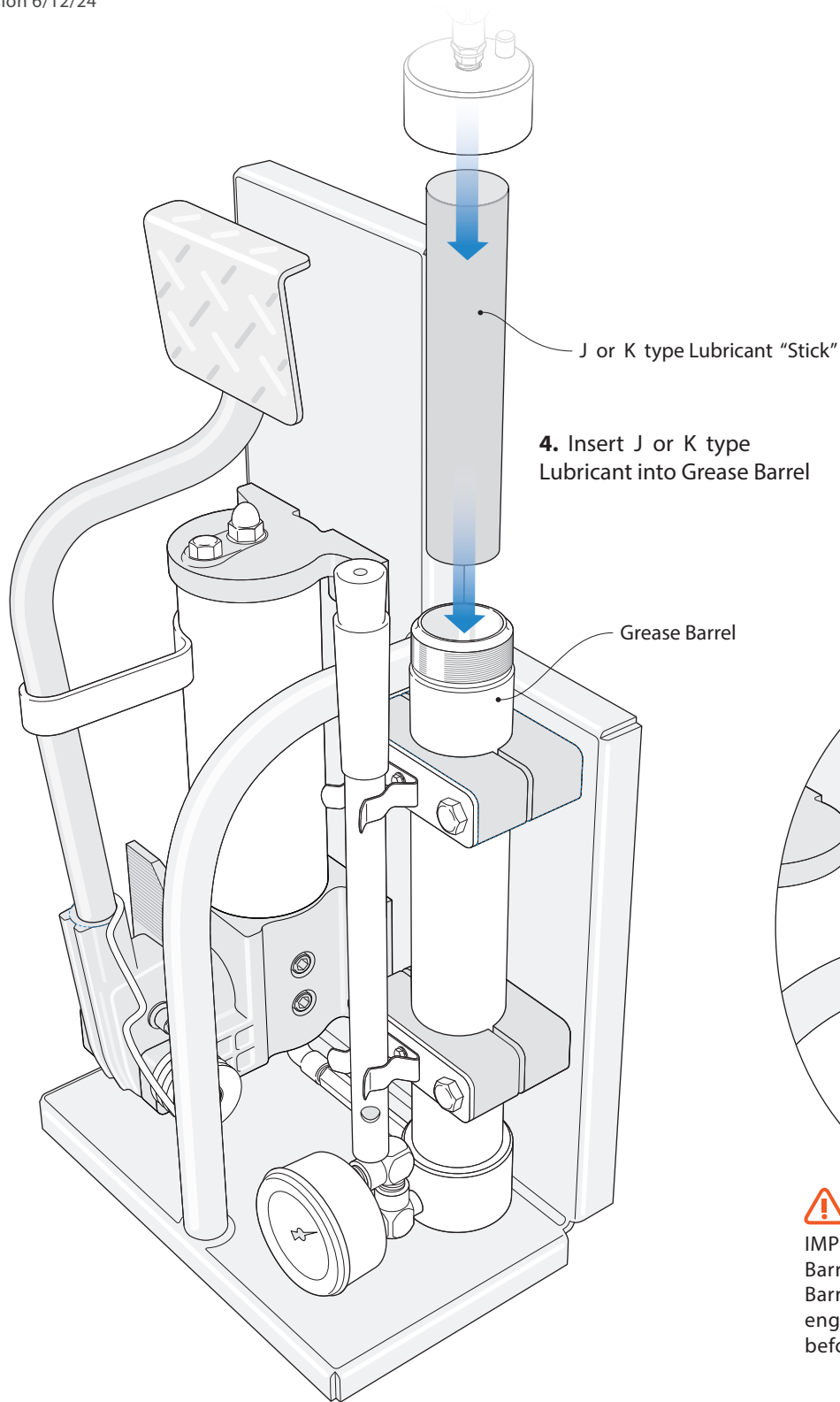

5. Replace Cap
Turn clockwise
until tight.

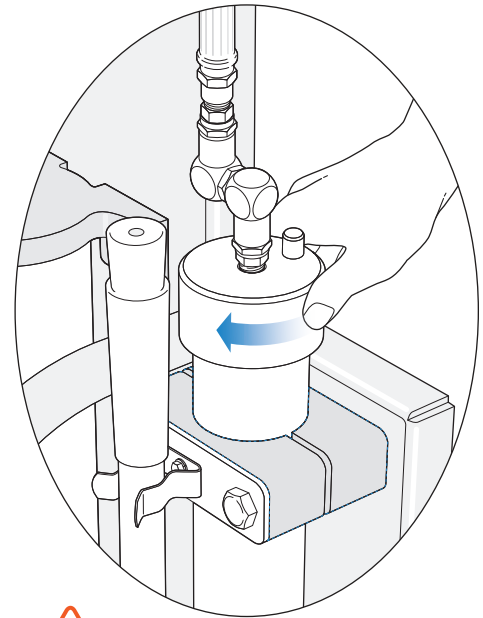

IMPORTANT - Always make sure the Grease Barrel Cap is firmly attached to the Grease Barrel, and be sure there is full thread engagement between these two parts before each Gun operation.